



US006412302B1

(12) **United States Patent**  
**Foglietta**

(10) **Patent No.:** **US 6,412,302 B1**  
(45) **Date of Patent:** **Jul. 2, 2002**

(54) **LNG PRODUCTION USING DUAL INDEPENDENT EXPANDER REFRIGERATION CYCLES**

(75) Inventor: **Jorge H. Foglietta**, Missouri City, TX (US)

(73) Assignee: **ABB Lummus Global, Inc. - Randall Division**, Houston, TX (US)

(\*) Notice: Subject to any disclaimer, the term of this patent is extended or adjusted under 35 U.S.C. 154(b) by 0 days.

4,461,634 A	*	7/1984	Duckett et al.	62/611
4,755,200 A	*	7/1988	Liu et al.	62/612
4,911,741 A	*	3/1990	Davis et al.	62/613
5,036,671 A	*	8/1991	Nelson et al.	62/612
5,651,269 A	*	7/1997	Prevost et al.	62/613
5,755,114 A	*	5/1998	Foglietta	62/618
6,041,619 A	*	3/2000	Fischer et al.	62/612
6,105,389 A	*	8/2000	Paradowski et al.	62/613

\* cited by examiner

(21) Appl. No.: **09/828,551**

(22) Filed: **Apr. 6, 2001**

**Related U.S. Application Data**

(60) Provisional application No. 60/273,531, filed on Mar. 6, 2001.

(51) **Int. Cl.**<sup>7</sup> ..... **F25J 1/00**; **F25J 3/00**

(52) **U.S. Cl.** ..... **62/611**; **62/619**

(58) **Field of Search** ..... **62/611, 612, 613, 62/614, 619, 912, 606**

(56) **References Cited**

**U.S. PATENT DOCUMENTS**

4,057,972 A \* 11/1977 Sarsten ..... 62/612

*Primary Examiner*—William C. Doerrler

(74) *Attorney, Agent, or Firm*—Bracewell & Patterson LLP

(57) **ABSTRACT**

A process for producing a liquified natural gas stream that includes cooling at least a portion of a pressurized natural gas feed stream by heat exchange contact with first and second expanded refrigerants that are used in independent refrigeration cycles. The first expanded refrigerant is selected from methane, ethane and treated and pressurized natural gas. The second expanded refrigerant is nitrogen.

**21 Claims, 4 Drawing Sheets**

**Production of LNG Using Dual Independent Expander Refrigeration Cycles**

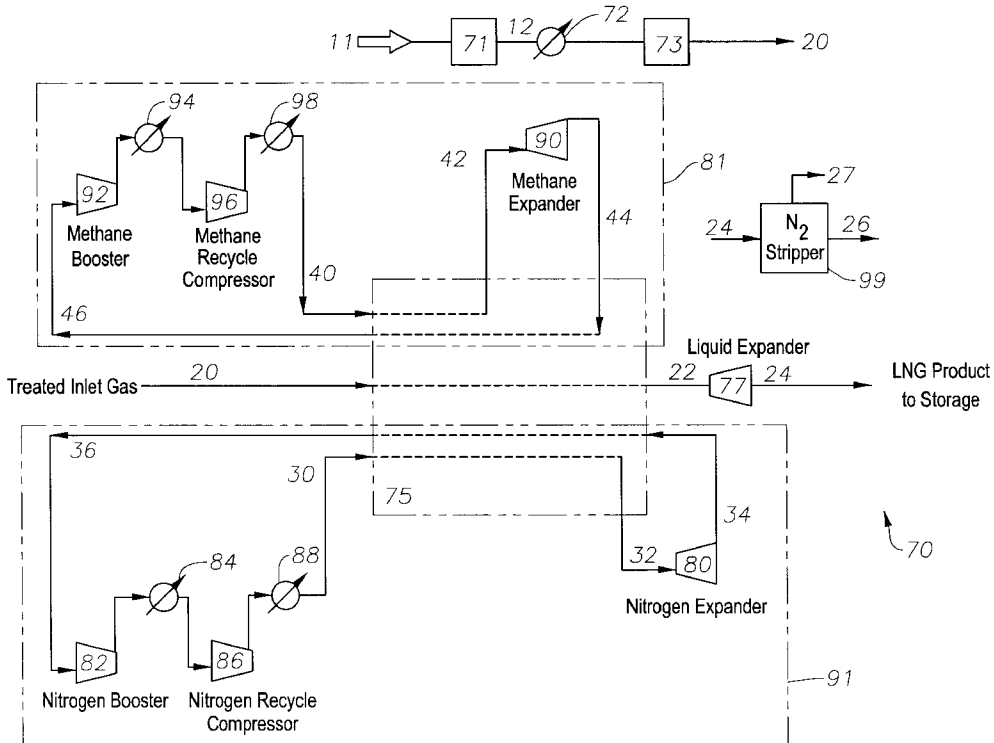



Production of LNG Using Dual Independent Expander Refrigeration Cycles

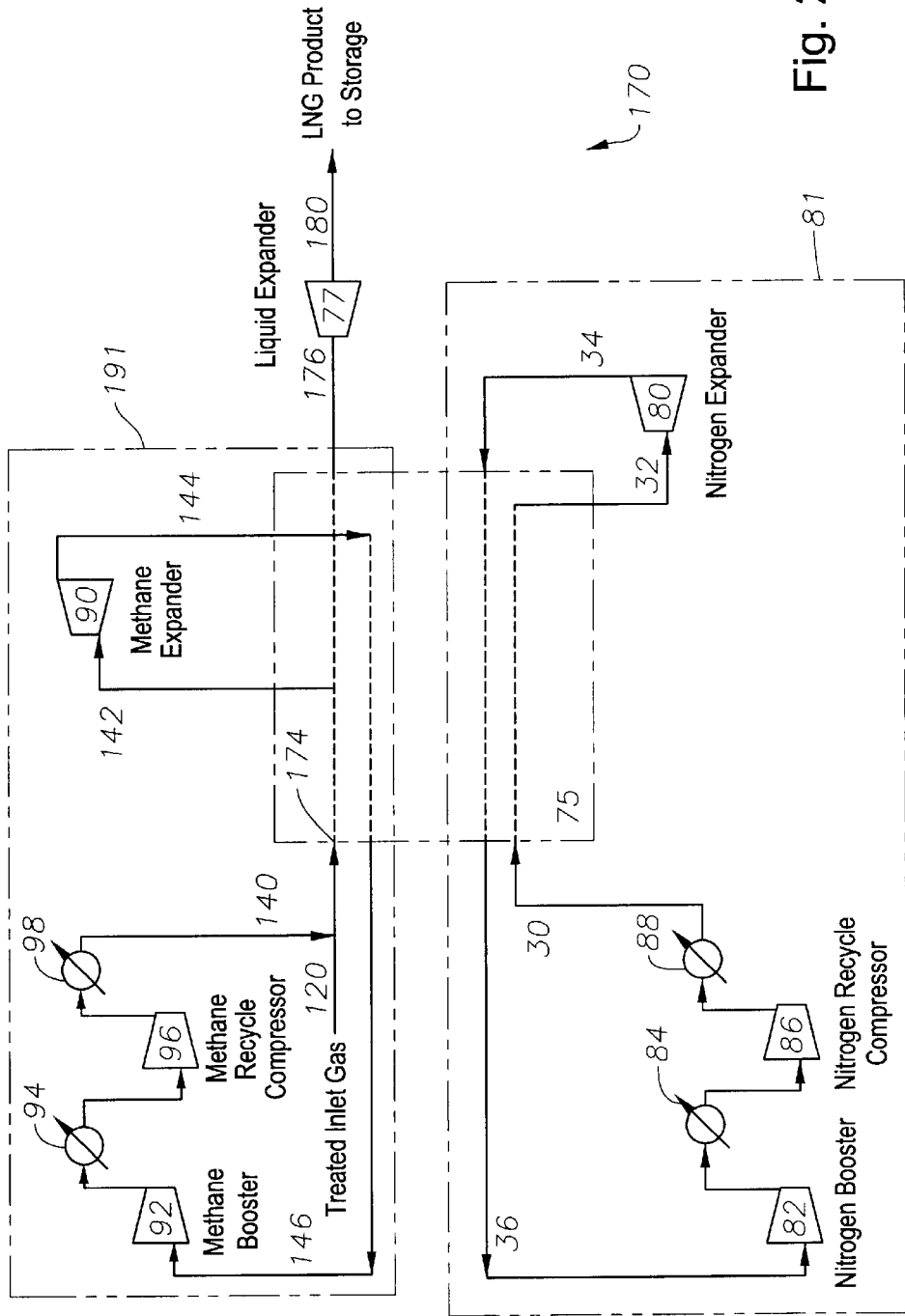
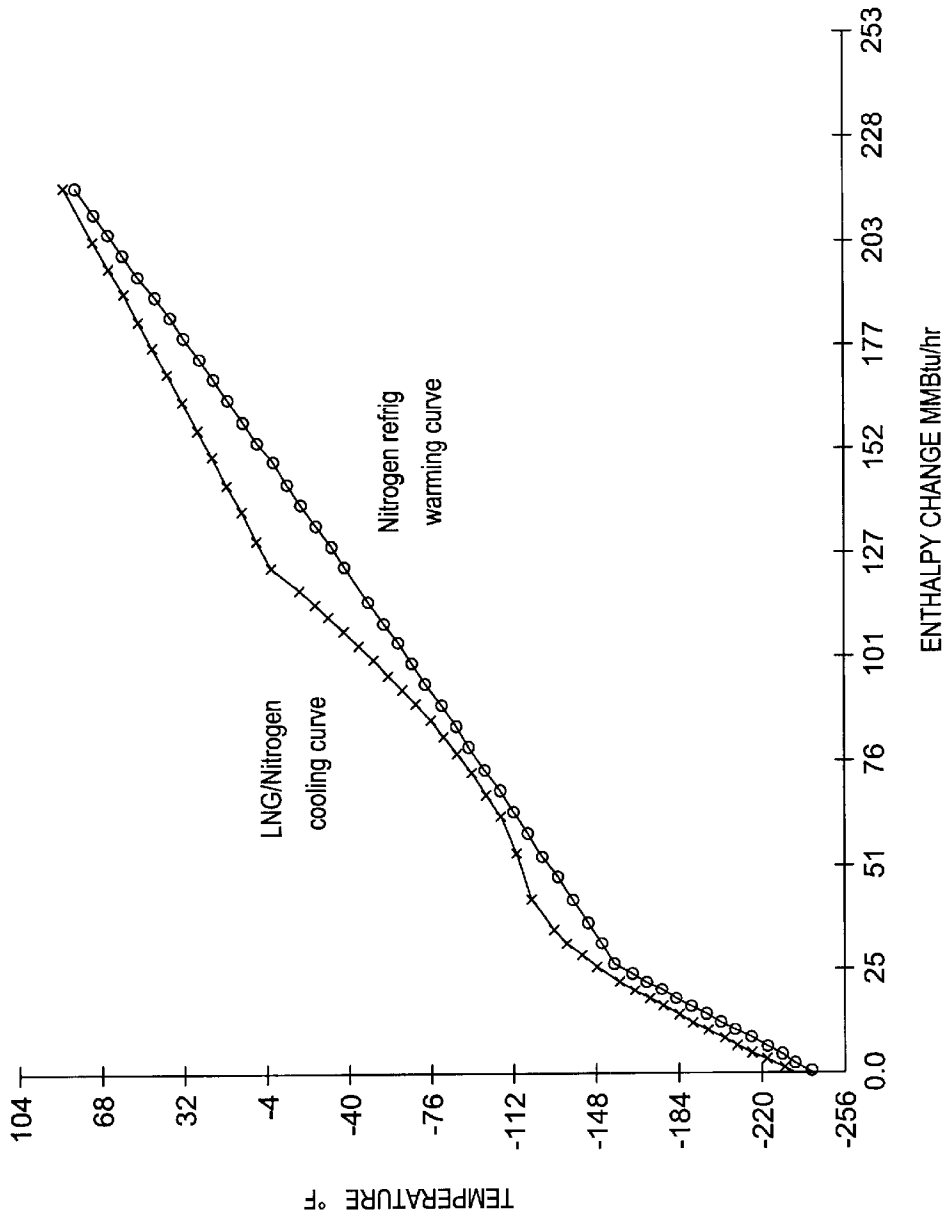
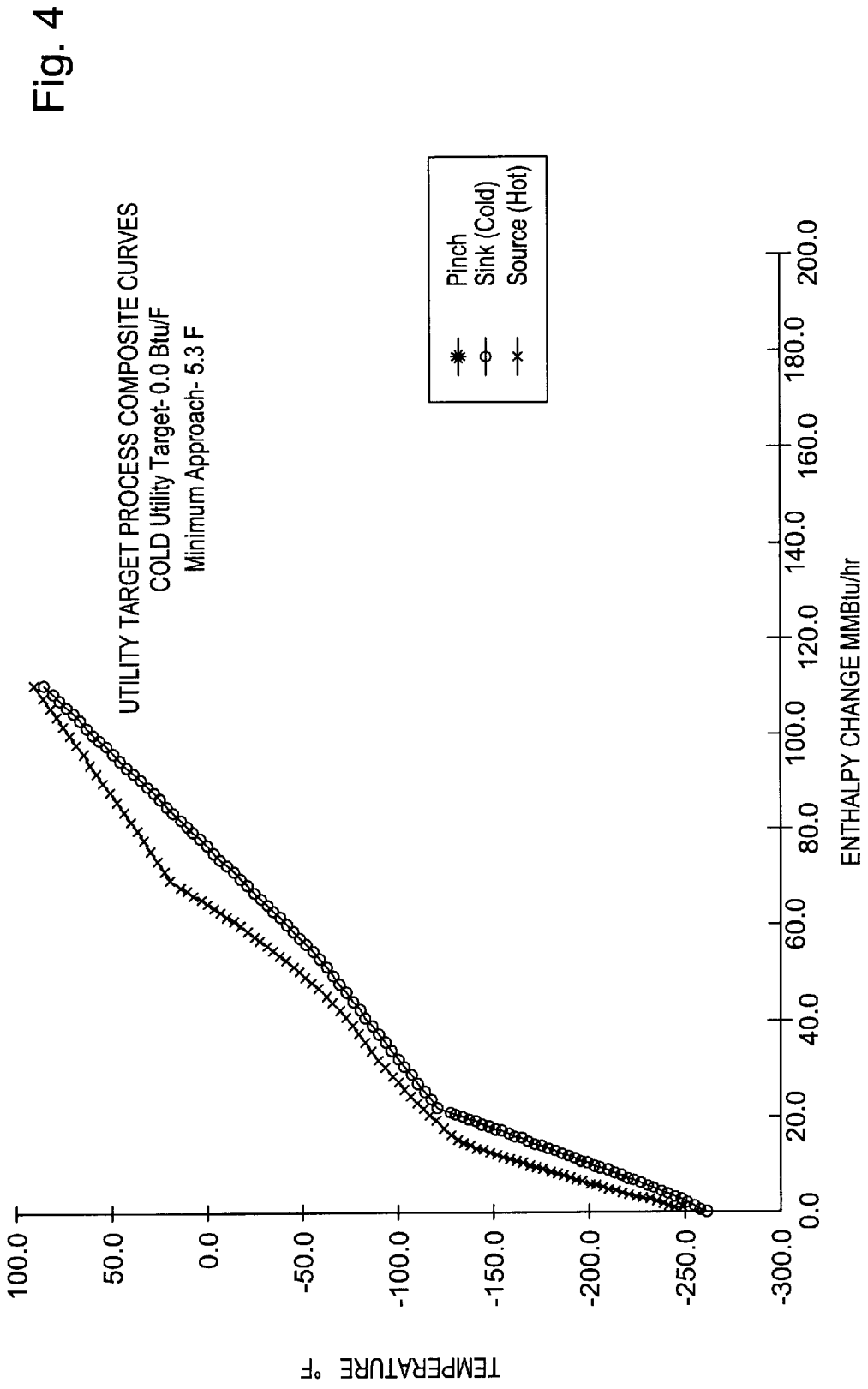

Fig. 2

Fig. 3  
(Prior Art)





## LNG PRODUCTION USING DUAL INDEPENDENT EXPANDER REFRIGERATION CYCLES

This application claims the benefits of provisional patent application, U.S. Ser. No. 60/273,531, filed on Mar. 6, 2001.

### BACKGROUND OF THE INVENTION

#### 1. Technical Field

This invention relates to a liquefaction process for a pressurized hydrocarbon stream using refrigeration cycles. More particularly, this invention relates to a liquefaction process for an inlet hydrocarbon gas stream using dual, independent refrigeration cycles having at least two different refrigerants.

#### 2. Background of the Invention

Hydrocarbon gases, such as natural gas, are liquified to reduce their volume for easier transportation and storage. There are numerous prior art processes for gas liquefaction, most involving mechanical refrigeration or cooling cycles using one or more refrigerant gases.

U.S. Pat. Nos. 5,768,912 and 5,916,260 to Dubar disclose a process for producing a liquefied natural gas product where refrigeration duty is provided by a single nitrogen refrigerant stream. The refrigerant stream is divided into at least two separate streams which are cooled when expanded through separate turbo-expanders. The cooled, expanded nitrogen refrigerant cross-exchanged with a gas stream to produce liquified natural gas.

There is a need for simplified refrigeration cycles for the liquefaction of natural gas. Conventional liquefaction refrigeration cycles use refrigerants which undergo a change of phase during the refrigeration cycle which require specialized equipment for both liquid and gas refrigerant phases.

The invention disclosed herein meets these and other needs.

### SUMMARY OF THE INVENTION

This invention is a cryogenic process for producing a liquified natural gas stream that includes the steps of cooling at least a portion of an inlet hydrocarbon gas feed stream by heat exchange contact with a first refrigeration cycle having a first expanded refrigerant and a second refrigeration cycle having a second expanded refrigerant that are operated in dual, independent refrigeration cycles. The first expanded refrigerant is selected from methane, ethane and other hydrocarbon gas, preferably treated inlet gas. The second expanded refrigerant is nitrogen. These dual, independent refrigerant cycles may be operated at the same time or operated independently.

### BRIEF DESCRIPTION OF THE DRAWINGS

So that the manner in which the features, advantages and objects of the invention, as well as others which will become apparent, may be understood in more detail, more particular description of the invention briefly summarized above may be had by reference to the embodiment thereof which is illustrated in the appended drawings, which form a part of this specification. It is to be noted, however, that the drawings illustrate only a preferred embodiment of the invention and is therefore not to be considered limiting of the invention's scope as it may admit to other equally effective embodiments.

FIG. 1 is a simplified flow diagram of dual, independent expander refrigeration cycles operated in accordance with

the present invention wherein a nitrogen stream and/or a methane stream are used as refrigerants

FIG. 2 is a simplified flow diagram of another embodiment of the invention of FIG. 1 wherein a nitrogen stream and/or an inlet gas stream are used as refrigerants.

FIG. 3 is a plot of a comparison of a nitrogen warming curve and a LNG/Nitrogen cooling curves for a prior art process.

FIG. 4 is a plot of a comparison of a refrigerant warming curve and a LNG/nitrogen/methane cooling curve for the present invention.

### DETAILED DESCRIPTION OF PREFERRED EMBODIMENT

The present invention is directed to an improved process for the liquefaction of hydrocarbon gases, preferably a pressurized natural gas, which employs dual, independent refrigerant cycles having a first refrigeration cycle using an expanded nitrogen refrigerant and a second refrigeration cycle using a second expanded hydrocarbon. The second expanded hydrocarbon refrigerant may be pressurized methane or treated inlet gas.

As used herein, the term "inlet gas" will be taken to mean a hydrocarbon gas that is substantially comprised of methane, for example, 85% by volume methane, with the balance being ethane, higher hydrocarbons, nitrogen and other trace gases.

The detailed description of preferred embodiments of this invention is made with reference to the liquefaction of a pressurized inlet gas which has an initial pressure of about 800 psia at ambient temperature. Preferably, the inlet gas will have an initial pressure between about 500 to about 1200 psia at ambient temperature. As discussed herein, the expanding steps, preferably by isentropic expansion, may be effectuated with a turbo-expander, Joule-Thompson expansion valves, a liquid expander or the like. Also, the expanders may be linked to corresponding staged compression units to produce compression work by gas expansion.

Referring now to FIG. 1 of the drawings, a pressurized inlet gas stream, preferably a pressurized natural gas stream, is introduced to the process of this invention. In the embodiment illustrated, the inlet gas stream is at a pressure of about 900 psia and ambient temperature. Inlet gas stream **11** is treated in a treatment unit **71** to removed acid gases, such as carbon dioxide, hydrogen sulfide, and the like, by known methods such as desiccation, amine extraction or the like. Also, the pretreatment unit **71** may serve as a dehydration unit of conventional design to remove water from the natural gas stream. In accordance with conventional practice in cryogenic processes, water may be removed from inlet gas streams to prevent freezing and plugging of the lines and heat exchangers at the low temperatures subsequently encountered in the process. Conventional dehydration units are used which include gas desiccants and molecular sieves.

Treated inlet gas stream **12** may be pre-cooled via one or more unit operations. Stream **12** may be pre-cooled via cooling water in cooler **72**. Stream **12** may be further pre-cooled by a conventional mechanical refrigeration device **73** to form pre-cooled and treated stream **19** ready for liquefaction as treated inlet gas stream **20**.

Treated inlet gas stream **20** is supplied to a refrigeration section **70** of a liquid natural gas manufacturing facility. Stream **20** is cooled and liquified in exchanger **75** by countercurrent heat exchange contact with a first refrigeration cycle **81** and a second refrigeration cycle **91**. These

refrigeration cycles are designed to be operated independently and/or concurrently depending upon the refrigeration duty required to liquify an inlet gas stream.

In a preferred embodiment, a first refrigeration cycle **81** uses an expanded methane refrigerant and a second refrigeration cycle **91** uses an expanded nitrogen refrigerant. In the first refrigeration cycle **81**, expanded methane is used as a refrigerant. A cold, expanded methane stream **44** enters exchanger **75**, preferably at about  $-119^{\circ}$  F. and about 200 psia and is cross-exchanged with treated inlet gas **20** and compressed methane stream **40**. Methane stream **44** is warmed in exchanger **75** and then enters one or more compression stages as stream **46**. Warm methane stream **46** is partially compressed in a first compression stage in methane booster compressor **92**. Next, stream **46** is then compressed again in a second compression stage in methane recycle compressor **96** to a pressure from about 500 to 1400 psia. Stream **46** is water cooled in exchangers **94** and **98** and enters exchanger **75** as compressed methane stream **40**. Stream **40** enters exchanger **75** at about  $90^{\circ}$  F. and preferably about 1185 psia. Stream **40** is cooled to about  $20^{\circ}$  F. and about 995 psia by cross-exchange with cold, expanded methane stream **44** and exits exchanger **75** as cooled methane stream **42**. Stream **42** is preferably isentropically expanded in expander **90**, to about  $-110$  to  $-130^{\circ}$  F., preferably to about  $-119^{\circ}$  F. and about 200 psia. Stream **42** enters exchanger **75** as cold, expanded methane stream **44**.

In the second refrigeration cycle **91**, a cold, expanded nitrogen stream **34** enters exchanger **75** at preferably about  $-260^{\circ}$  F. and about 200 psia and is cross-exchanged with treated inlet gas stream **20** and compressed nitrogen stream **30**. Nitrogen stream **34** is warmed in exchanger **75** and then enters one or more compression steps as stream **36**. Warm nitrogen stream **36** is partially compressed in nitrogen booster compressor **82** and then compressed again in nitrogen recycle compressor **86** to a pressure from about 500 to 1200 psia. Stream **36** is water cooled in exchangers **84** and **88** and enters exchanger **75** as compressed nitrogen stream **30**. Stream **30** enters exchanger **75** at about  $90^{\circ}$  F. and preferably about 1185 psia. Stream **30** is cooled to preferably about  $-130^{\circ}$  F. and about 1180 psia by cross-exchange with cold, expanded nitrogen stream **34** and exits exchanger **75** as cooled nitrogen stream **32**. Stream **32** is preferably isentropically expanded in expander **80** to about  $-250$  to  $-280^{\circ}$  F., preferably to about  $-260^{\circ}$  F. and about 200 psia. Stream **32** enters exchanger **75** as cold, expanded nitrogen stream **34**.

The first and second dual, independent refrigeration cycles work independently to cool and liquefy inlet gas stream **20** from about  $-240$  to  $-260^{\circ}$  F., preferably to about  $255^{\circ}$  F. Liquefied gas stream **22** is preferably isentropically expanded in expander **77** to a pressure from about 15 to 50 psia, preferably to about 20 psia to produce a liquefied gas product stream **24**.

Product stream **24** may contain nitrogen and other trace gases. To remove these unwanted gases, stream **24** is introduced to a nitrogen removal unit **99**, such as a nitrogen stripper, to produce a treated product stream **26** and a nitrogen rich gas **27**. Rich gas **27** may be used for low pressure fuel gas or recompressed and recycled with the inlet gas stream **11**.

In another preferred embodiment, treated inlet gas may be used to supply at least a portion of refrigeration duty required by the process. As shown in FIG. 2, the first refrigeration cycle **191** uses an expanded hydrocarbon gas mixture as a refrigerant. The hydrocarbon gas mixture

refrigerant is selected from methane, ethane and inlet gas. The second refrigeration cycle operates as discussed above.

In the first refrigeration cycle **191**, cold expanded hydrocarbon gas mixture **144** enters exchanger **75** at preferably about  $-119^{\circ}$  F. and 200 psia and is cross-exchanged with an inlet gas mixture **174** to be liquified. Gas mixture stream **144** is warmed in exchanger **75** and then enters one or more compression stages as stream **146**. Warm gas mixture stream **146** is partially compressed in a first compression stage in methane booster compressor **92**. Stream **146** is then compressed again in a second compression stage in methane recycle compressor **96** to a pressure from about 500 to 1400 psia. Stream **146** is water cooled in exchangers **94** and **98** as compressed gas mixture stream **140**. Preferably, treated inlet gas **120** is mixed with compressed gas mixture **140** to form stream **174** to be liquified. Also, treated inlet gas **120** may be mixed with stream **146** prior to entering one or more compression stages. Stream **174** enters exchanger **75** at preferably about  $90^{\circ}$  F. and about 1000 psia. Stream **174** is cooled to preferably about  $20^{\circ}$  F. and about 995 psia by cross-exchange with cold, expanded gas mixture stream **144** and exits exchanger **75** as cooled gas mixture stream **142**. Stream **142** is preferably isentropically expanded in expander **90** to about  $-110$  to  $-130^{\circ}$  F., preferably to about  $-119^{\circ}$  F. and about 200 psia. Stream **142** enters exchanger **75** as cold, expanded gas mixture stream **144**.

The first and/or second dual, independent refrigeration cycles work independently to cool and liquify inlet gas mixture **174** from about  $-240$  to  $-260^{\circ}$  F., preferably to about  $-255^{\circ}$  F. Liquefied gas mixture stream **176** is preferably isentropically expanded in expander **77** to a pressure from about 15 to 50 psia, preferably to about 20 psia to produce a liquefied gas mixture product stream **180**.

As noted above, the refrigerant gases in each dual, independent refrigeration cycle may be sent to their respective booster compressors and/or recycle compressors to recompress the refrigerant. The booster compressors and/or recycle compressors may be driven by a corresponding or operably linked turbo-expander in the process. In addition, the booster compressor may be operated in post-boost mode and located downstream from the recycle compressor to supply additional compression of about 50 to 100 psia to the refrigerant gases. The booster compressor may also be operated as pre-boosted mode and located upstream from the recycle compressor to partially compress the refrigerant gases about 50 to 100 psia before being sent to the final recycle compressors.

FIG. 3 illustrates warming and cooling curves for a prior art liquefaction process.

The warming curve of the nitrogen refrigerant is essentially a straight line having a slope which is adjusted by varying the circulation rate of nitrogen refrigerant until a close approximation is achieved between the warming curve of the nitrogen refrigerant and the cooling curve of the feed gas at the warm end of the exchanger. This sets the upper limit of operation of the liquefaction process. Thus, by using this prior art method it is possible to obtain relatively close approximations at both the warm and cold ends of the heat exchanger between the different curves. However, because of the different shapes of the respective curves in the intermediate portion of each it is not possible to maintain a close approximation between the two curves over the entire temperature range of the process, i.e. the two curves diverge from each other in their intermediate portions. Although the nitrogen refrigerant warming curve approximates a straight line, the cooling curve of the feed gas and nitrogen is of a

complex shape and diverges markedly from the linear warming curve of the nitrogen refrigerant. The divergence between the linear warming curve and the complex cooling curve is a measure of and represents thermodynamic inefficiencies or lost work in operating the overall process. Such inefficiencies or lost work are partly responsible for the higher power consumption of using the nitrogen refrigerant cycle compared to other processes such as the mixed refrigerant cycle.

FIG. 4 illustrates a warming and cooling curves for a preferred embodiment of this invention. This invention demonstrates improved thermodynamic efficiency or reduced lost work as compared to prior art gas liquefaction processes by utilizing the cooling capacity upon expansion of a hydrocarbon gas mixture, such as high pressure methane, ethane and/or inlet gas. In addition, thermodynamic efficiency is also improved over prior art processes because the dual, independent refrigeration cycles of the invention may be adjust and/or adapt to the particular refrigeration duty needed to liquefy a given inlet gas stream of known pressure, temperature and composition. That is, there is no need to supply more refrigeration duty that is required. As a result, the warming and cooling curves are more closely matched so that the temperature gradients and hence thermodynamic losses between the refrigerant and inlet gas stream are reduced.

In the process illustrated in FIG. 1, the warming curve is divided into two discrete sections by splitting the refrigeration duty required to liquefy the inlet gas into two refrigeration cycles. In the first cycle, a hydrocarbon gas mixture, such as methane refrigerant is expanded, preferably in a turbo-expander, to a lower pressure at a lower temperature and provides cooling of the inlet gas stream. The second cycle is used where a nitrogen refrigerant is expanded, preferably in a turbo-expander, to a lower pressure and temperature and provides further cooling of the gas stream. The flow rate of the refrigeration in the second cycle is chosen so that the slope of the warming curve is approximately the same as that of the cooling curve. Because of the shape and slope of the cooling curves in the last portion of the cooling process, it is the nitrogen cycle that provides the major portion of the refrigeration duty in this invention. As a result, the minimum temperature approach of approximately 5° F. is achieved throughout the exchanger.

The invention has significant advantages. First, the process is adaptable to different quality of the feed inlet gas by adjusting the relationship between the nitrogen and/or gas refrigerants and thereby more thermodynamically efficient. Second, the circulating refrigerants are in the gaseous phase. This eliminates the need for liquid separators or liquid storage and the concomitant environmental safety impacts. Gas phase refrigerants simplify the heat exchanger construction and design.

While the present invention has been described and/or illustrated with particular reference to the process for the liquefaction of hydrocarbons, such as natural gas, in which nitrogen and a second refrigerant, such as methane or other hydrocarbon gas, is used as refrigerants in dual, independent cycles, it is noted that the scope of the present invention is not restricted to the embodiment(s) described. It should be apparent to those skilled in the art that the scope of the invention includes other methods and applications of the process using nitrogen and/or to the use of other gases in the improved application or in other applications than those specifically described. Moreover, those skilled in the art will appreciate that the invention described above is susceptible to variations and modifications other than those specifically

described. It is understood that the present invention includes all such variations and modifications which are within the spirit and scope of the invention. It is intended that the scope of the invention not be limited by the specification, but be defined by the claims set forth below.

It is claimed:

1. A process for producing a liquefied natural gas stream from an inlet gas feed stream, the process comprising the steps of:

cooling at least a portion of the inlet gas feed stream by heat exchange contact with first and second expanded refrigerants, wherein at least one of the first and second expanded refrigerants is circulated in a gas phase refrigeration cycle, whereby a liquefied natural gas stream is produced.

2. The process of claim 1 wherein the first expanded refrigerant is selected from the group consisting of methane, ethane and inlet gas.

3. The process of claim 1 wherein the second expanded refrigerant is nitrogen.

4. The process for producing a liquefied natural gas stream of claim 1 wherein the first and second expanded refrigerants are expanded in a device selected from the group consisting of an expansion valve, a turbo-expander and a liquid expander.

5. The process of claim 1 wherein the liquefied natural gas stream is cooled to a temperature of about -240° F. to about -260° F.

6. The process of claim 1 wherein the inlet gas stream is at an inlet pressure of about 500 psia to about 1200 psia.

7. The process of claim 1 wherein a cooling curve for the first and second refrigerants approaches a cooling curve for the inlet gas feed stream by at least about 5° F.

8. The process of claim 1 wherein the cooling step includes cooling at least a portion of the inlet gas feed stream with a mechanical refrigeration cycle.

9. The process of claim 8 wherein the mechanical refrigeration cycle includes a refrigerant selected from the group consisting of propane and propylene.

10. The process of claim 1 or 8 wherein the cooling step includes cooling at least a portion of the inlet gas feed stream with cooling water.

11. A process for producing a liquefied natural gas stream from an inlet gas feed stream, the process comprising the steps of:

cooling at least a portion of the inlet gas feed stream by heat exchange contact with a first refrigeration cycle operated independently of a nitrogen refrigeration cycle;

the first refrigeration cycle comprising the steps of:  
expanding a refrigerant stream to form a cold refrigerant vapor stream;

cooling at least a portion of the inlet feed gas stream by heat exchange contact with the cold refrigerant vapor stream;

compressing the cold refrigerant vapor stream to form a compressed refrigerant vapor stream; and

cooling at least a portion of the compressed refrigerant vapor stream by heat exchange contact with the cold refrigerant vapor stream; and

the nitrogen refrigeration cycle comprising the steps of:  
expanding a nitrogen stream to a cold nitrogen vapor stream;

cooling at least a portion of the inlet feed gas stream by heat exchange contact with the cold nitrogen vapor stream;

compressing the cold nitrogen vapor stream to form a compressed nitrogen vapor stream; and



7

cooling at least a portion of the compressed nitrogen vapor stream by heat exchange contact with the cold nitrogen vapor stream;

whereby a liquified natural gas stream is produced.

**12.** The process for producing a liquified natural gas stream of claim **11** wherein the refrigerant stream in the first refrigeration cycle is selected from the group consisting of methane, ethane and inlet gas.

**13.** The process for producing a liquified inlet gas stream of claim **12** wherein the compressing step of the first refrigeration cycle includes mixing at least a portion of the inlet gas feed stream with the compressed refrigerant vapor stream to form the refrigerant stream.

**14.** The process for producing a liquified natural gas stream of claim **13** wherein the expanding step of the first refrigeration cycle includes expanding the refrigerant stream to a temperature of about  $-110^{\circ}$  F. to about  $-130^{\circ}$  F.

**15.** The process for producing a liquified natural gas stream of claim **11** wherein the expanding step of the nitrogen refrigeration cycle includes expanding the nitrogen stream to a temperature of about  $-250^{\circ}$  F. to about  $-280^{\circ}$  F.

**16.** The process for producing a liquified natural gas stream of claim **11** wherein the expanding step in the first and nitrogen refrigeration cycles is provided by an expan-

8

sion device selected from the group consisting of an expansion valve, a turbo-expander and a liquid expander.

**17.** The process for producing a liquified natural gas stream of claim **11** wherein the compressed nitrogen vapor stream of the nitrogen refrigeration cycle is compressed to a pressure of about 500 psia to about 1200 psia.

**18.** The process for producing a liquified natural gas stream of claim **11** wherein the compressed refrigerant vapor stream of the first refrigerant cycle is compressed to a pressure of about 500 psia to about 1400 psia.

**19.** The process for producing a liquified natural gas stream of claims **1** or **11** further comprising the step of removing nitrogen and other trace gases from the liquified natural gas stream.

**20.** The process of claims **1** or **11** further comprising the step of expanding the liquified natural gas stream to a pressure from about 15 psia to about 50 psia.

**21.** The process of claim **1** wherein the cooling at least a portion of the inlet feed stream is performed by heat exchange contact with at least one of the gas phase refrigeration cycles.

\* \* \* \* \*